

PRECAUTIONS FOR HANDLING VALVE REGULATED (SEALED) LEAD-ACID BATTERIES

Precautions for handling Valve Regulated (Sealed) Lead-Acid Batteries

- This document should be read in its entirety and its contents fully understood before handling or using rechargeable Valve Regulated (Sealed) Lead-Acid batteries. If there are any questions, please contact Voltus Battery Corporation. Please keep this document available for reference. Due to the potential energy stored in the batteries, improper handling or use of the batteries without understanding this document may result in bodily injury caused by electrolyte leakage, heat generation, or explosion.

* All descriptions are subject to modification without notice.

Degree of danger

1. DANGER

When the batteries are handled or used improperly, death or severe injury shall occur.

2. WARNING

When the batteries are handled or used improperly, death or severe injury may occur, and sight injury or loss of products often occur.

3. CAUTION

When the batteries are handled or used improperly, slight injury may occur and damage to the batteries and equipment may occur.

4. REQUEST

When the batteries are handled or used improperly, damage to theft quality or performance may occur.

Note (1): Improper handling and use of the batteries may cause dangerous conditions to arise. All precautions should be taken to prevent any harmful effects from the use of the batteries.

Note (2): "Severe injury" as a result of improper handling or use of the batteries may include but are not limited to loss of eyesight, injury/burn/electric shock/fracture of a bone/poisoning with after effect, or injury that requires long-term medical treatment. "Slight injury" covers such conditions as burns or electric shock that do not require long-term medical treatment. Damage to products is defined as extensive damage to a house, a house hold effects, a livestock, or pets.

Note (3): "Requests" are meant to prevent a decrease in the quality or the performance of the batteries.

INDEX

- Environments and Conditions
- Installation
- Preparation Prior to Operation
- Unspecified Use
- Methods of Handling and Operation
- Maintenance
- Treatment at Emergencies
- Storage
- Disposal and Recycling

Safety Precautions

1. Environment and Condition

DANGER

- (1) Do not put the batteries into airtight containers or bags. The batteries tend to generate inflammable gas upon excess charge which may cause an explosion if enclosed in an airtight container.

WARNING

- (1) The batteries must be charged using the specified charger or by maintaining the charging conditions indicated by Voltus Battery Corporation. If the batteries are charged under conditions other than those specified by Voltus Battery Corporation, they may leak, ignite, or explode.
- (2) When using the batteries in medical equipment, incorporate a back-up system other than the main battery in the event of power failure.
- (3) Insert insulation that is resistant to heat and sulfuric acid between the batteries and any metallic housing. Failure to do so may cause the batteries to smoke or burn in case of electrolyte leakage.
- (4) Do not place the batteries near a device that may generate sparks (such as a switch or fuse) and do not place the batteries close to fire. The batteries may generate an inflammable gas when charged excessively that may ignite upon contact with a spark, burn or explode.
- (5) Avoid placing batteries near a heat-generating device (such as a transformer) which may cause the batteries to leak, ignite, or explode.

CAUTION

- (1) Use or store the batteries in the temperature range specified below:
Discharge(operating an application): -15°C~50°C.
Charged: 0°C to 40°C.
Storage: -15°C to 40°C.
Temperatures above or below those recommended may quicken damage or deformity of the batteries.
- (2) Do not allow the batteries to be exposed to rain or sea water. If the battery terminals should get wet, they may corrode and cause an electric shock or an ignite.
- (3) Do not use or store the batteries in a car under the blazing sun, in direct sunlight. To do so may cause the batteries to leak, ignite, or explode.
- (4) Do not use or store the batteries in a dusty place as dust may cause them to short between their terminals. When using the batteries in a dusty place, check them periodically.
- (5) In applications requiring more than one battery, first connect the batteries together and then connect the batteries to the charger or the load. Be careful to connect the (+)pole of the batteries to the (+) terminal of either the charger or the load. Improperly connecting the batteries, charger or load may cause an ignition or explosion to occur. In some cases, bodily injury may occur.
- (6) When handling the batteries, wear steel-tipped shoes to prevent possible injury to the feet if the batteries are accidentally dropped.

REQUEST

- (1) Dropping a battery may cause a strong physical shock that may damage the performance of the battery.
- (2) Confirm the life of the batteries using the real load and charger. Differences in the charging and the discharging conditions may cause a big difference in the life of the batteries.

PRECAUTIONS FOR HANDLING VALVE REGULATED (SEALED) LEAD-ACID BATTERIES-CONTINUED

2. Installation

DANGER

- (1) Tools such as wrenches used to install the batteries should be insulated. Bare metal tools may cause an abnormal short circuit accident to occur resulting in bodily injury, damage to the batteries, explosion or ignition.
- (2) Do not install the batteries in a room without ventilation. The batteries tend to generate an inflammable gas upon excess charge resulting in an ignition or explosion if the room is closed.

WARNING

- (1) Do not contact any plastic or resin (*) which contains a migrating plasticizer with the batteries. Furthermore, avoid using organic solvents such as thinner, gasoline, lamp oil, benzine and liquid detergent to clean the batteries. The use of any of above materials may cause the containers and /or the covers (ABS resin) of the batteries to crack and leak. This may cause a fire in the worst scenario. Need to make sure the use of material will not cause the containers and/ or the covers (ABS resin) of the batteries to crack due to the migration of plasticizer within the material by asking the manufacturer of the material if necessary.

* Examples for plastic or resin which should be avoided using;
Vinyl chloride, Oily rubber.

* Examples for plastic or resin which is proper for the use;
Polyolefin resin such as polypropylene, polyethylene.

- (2) Always use such as rubber gloves when handling batteries with the voltages higher than 45 volts in order to prevent severe bodily injury from occurring.
- (3) Do not install the batteries in areas where they may come in contact with water. If the batteries come in contact with water, an electric shock or an ignition may occur.

CAUTION

- (1) During unpacking, handle the batteries carefully and check for cracks, breakage, or electrolyte leakage. Failure to handle carefully may result in damage due to physical shock.
- (2) When the batteries are being mounted in the equipment, consider the best position for easy checking, maintenance and replacement. In addition, the batteries should be located in the low-

est part of the equipment as possible. The Rechargeable Sealed Lead-Acid batteries, mentioned in this document, are designed for use in any position, but charging the batteries in the upside-down position should be avoided. When these batteries are charged excessively in the upside-down position, leakage of electrolyte from the rubber vents may occur. The upside-down is shown on the left side of the next drawings. In this upside-down position, the mark "Voltus" on the battery are turned upside down. The drawings are only for explanation of the battery's position; therefore these are not equal to the real appearance of the battery that the specifications describe.

Can be used in the vertical position and the side-down position (maximum angle of 90 degrees from the normal position).

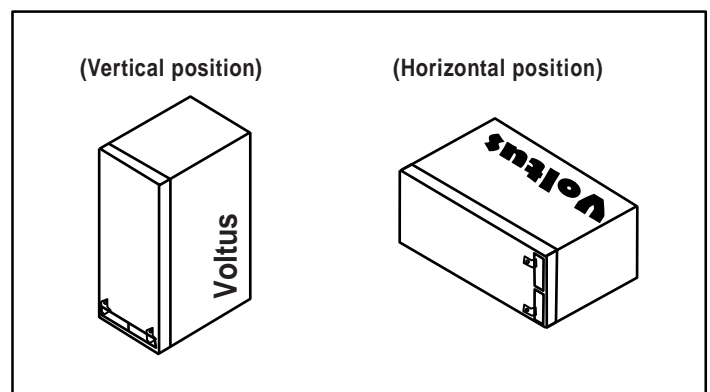
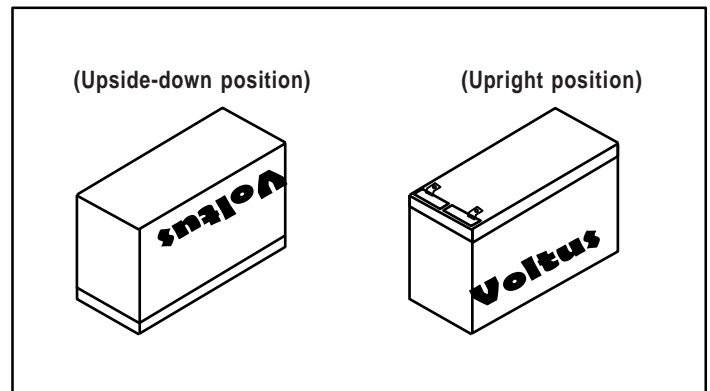

- (3) Do not carry the batteries by picking up them by their terminals or lead wires. To do so may damage the batteries.
- (4) Be careful not to jolt the batteries as it may result in damage to them.

PRECAUTIONS FOR HANDLING VALVE REGULATED (SEALED) LEAD-ACID BATTERIES-CONTINUED

- (5) Be aware the batteries are relatively heavy compared to their volume. Not to be so may cause injury and/or lumbago.
- (6) Do not cover the batteries with plastic sheet as it may cause a fire or an explosion by conducting static electricity.
- (7) Fasten the bolts and the nuts with the torque as shown below: Not to do so may cause the battery terminals to spark and/or break.
- (8) Place the necessary insulating covers over the terminals, the connecting bars, and bolts and nuts to prevent a dangerous electric shock.
- (9) Please consult Voltus Battery Corp prior to using the batteries in applications such as a motor bicycle, an engine driven lawn mower, etc. which may generate severe vibration.
- (10) Fasten the batteries firmly to the equipment to avoid the influence of vibration and/or physical shock.

Bolt (nut) size (mm)			Fastening torque N·m
Diameter	Pitch	Length	
M5 (5)	0.8	15 ± 1	2.0-2.9
M6 (6)	1.0	20 ± 1	3.9-5.4
M8 (8)	1.25	20 ± 1	7.8-9.8

REQUEST

- (1) The batteries should be installed by a certified technician.

3. Preparation Prior to Operation

DANGER

- (1) Be sure to provide enough insulation around the lead wires and/or plates used between the batteries and the application. Insufficient insulation may cause an electric shock heat generating from a short circuit(or excess current) may result in an injury, burn, smoke or ignition.

CAUTION

- (1) Do not plug the batteries directly into the outlet or the cigarette receptacle of a car without inserting a charger between the batteries and the outlet or the receptacle. To do so may cause electrolyte leakage, ignition or explosion of the battery.
- (2) Turn off the circuit switch when the connections between the batteries and the charger/load are made.
- (3) When using the batteries for the first time, check for rust, heat generation, or -any other abnormalities. If found, do not use as it may cause electrolyte leakage, heat generation, or explosion.

REQUEST

- (1) Since the batteries tend to lose a part of their capacity due to self-discharge during shipment and storage, recharge the batteries before you use them after purchase or long-term storage in order to restore their full capacity. Check for the following conditions before to recharge:

Charging method	Charging condition (at 250C)
Constant voltage	<ul style="list-style-type: none"> <input type="checkbox"/> Regulation range of the controlled voltage 7.25V to 7.45V 6V battery, 14.5V to 14.9V 12V battery; Initial current 0.1CA to 0.4CA; Maximum charging time 24 hours. <input type="checkbox"/> Short-time charge is possible when several batteries of the same model, under the same storage conditions can be charged in series. Otherwise they can be charged separately.
Constant current	<ul style="list-style-type: none"> <input type="checkbox"/> Charging current 0.1CA <input type="checkbox"/> Charging time (hours)=[Amount of self- discharge (Ah) 0.1CA] x 120% <input type="checkbox"/> Rough estimation of amount of self-discharge is as follows (for an example) When the storage ambient temperature is lower than 25oC, and storage time is known, assume the following amount of self-discharge [5% month] x storage months <input type="checkbox"/> Multiply this by the rated capacity (at 20 hour rate) of the battery <input type="checkbox"/> Regardless of the above calculation, the charge time for a refresh charge must be less than 12 hours. <input type="checkbox"/> When the storage ambient temperature is higher than 25oC, please consult Voltus Battery.

4. Unspecified Use

CAUTION

- (1) Do not place the batteries in an unspecified use or they may leak, ignite or explode.

5. Method of Handling and Operation

DANGER

- (1) The batteries must be charged using the specified charger or by maintaining the charging conditions indicated by Voltus Battery Corporation. If the batteries are charged under conditions other than those specified by Voltus, they may leak, ignite or explode.
- (2) Do not directly connect the positive and negative terminals with a conductive material such as a wire. Be careful while using a metal tool such as a wrench and/or carrying the batteries with metallic necklaces and hairpins not to make a short circuit. A short of the battery's terminals may cause heat generation, an explosion or a fire.
- (3) Charging the batteries with an inverse polarity connection between the batteries and the charger could cause electrolyte leakage, an ignition or explosion.
- (4) Do not solder directly on the batteries' terminal tabs. Soldering directly on the batteries' terminals may cause a leak of electrolyte.
- (5) Avoid the use of the batteries differing in capacity, type, history of use (charge/discharge operation). These differences could cause electrolyte leakage or heat generation.
- (6) Do not remove or scratch the outer tube of the battery or it may cause an electrolyte leakage or electrical leakage.

WARNING

- (1) Never dispose of the batteries in a fire as it may cause them to explode or generate a toxic gas.
- (2) Do not attempt to disassemble the batteries as it could cause leakage of sulfuric acid that could bodily injure.
- (7) Do not allow the batteries to be subjected to any strong physical shocks or jolts while moving them. Treating the batteries roughly could cause leaks, heat generation, or a explosions.

CAUTION

- (1) To prevent accidents from happening, change any battery that is found to have an abnormality such as a crack, a deformity, or leakage. The batteries must be kept clean and free from dust to prevent loss of capacity or accident.
- (2) If any abnormality of the charge voltage or the discharge voltage is detected replace the batteries with new ones.
- (8) Do not charge the batteries beyond the amount of the time indicated in the specifications, or do not charge after the charge indication lamp indicates a full charge. Take the batteries off the charger if the charge is not finished after the specified charge time. Over-charging can cause leakage, ignition, or explosions.
- (9) Do not discharge the batteries beyond the maximum values indicated in the specifications. If the batteries are discharged beyond the maximum values, they may leak, ignite or explode.
- (10) Children should be taught how to handle and use the batteries correctly.
- (11) Keep the batteries out of the reach of small children at all times.

REQUEST

- (1) The cut-off voltage during discharge should vary depending on the discharge current. Do not discharge the batteries lower than the recommended cut-off voltage shown in Voltus specifications or Voltus technical handbooks. Recharging a battery which was once discharged below the recommended cut-off voltage may generate heat, resulting in the deformation of the battery or in condensation around the battery cover caused when moisture within the battery evaporates. In addition, the efficiency of the battery would eventually decrease. Overdischarging a battery may result in reduced performance. Always recharge the batteries immediately after discharge even if the batteries were not discharged to the recommended cut-off voltage. If the batteries are not charged soon after discharge, the batteries performance may be reduced due to the so-called "sulfation phenomena".

Note: The cut-off device to prevent overdischarge should cut off all discharge current including any weak current.
- (2) Thoroughly study the charge methods and the conditions of the batteries before adopting other charge methods which are not shown in the Voltus specifications.
- (3) When the batteries are used in a cyclic application, it is important to charge the batteries for the proper amount of time. A timer should be incorporated into the charging circuit that will disconnect the charging current to prevent overcharging. Also, it is important to allow the battery to completely charge before removing the battery from the charger.
- (4) Avoid parallel charging of the batteries in cycle use. This may shorten the life of the batteries by causing an imbalance in the charge/discharge operation of the batteries.
- (5) Measure the total voltage of the batteries during trickle charge (or float charge), using a voltage meter with the accuracy of Class 0.5(Japan Industrial Standard). If the total voltage of the batteries provide an indication deviating from the specified voltage range, be sure to investigate the cause. If the total voltage is lower than that specified, the batteries may lose their capacity because of a lack of sufficient charge. However, if the total voltage is higher than that specified, the batteries may lose their capacity by damage due to overcharge and may suffer from "thermal runaway" and other accidents.
- (6) Switch off the equipment after use to prevent loss of performance or shortened life of the batteries due to damage overdischarge.
- (7) When storing the batteries, be sure to remove them from the equipment or disconnect them from the charger and the load to prevent overdischarge and loss of capacity. Before storing batteries, charge the batteries fully. Do not store batteries in a highly humid place to prevent rust from forming on the terminals.

6. Maintenance

WARNING

- (1) When cleaning the batteries, use a soft damp cloth. A dry cloth may cause static electricity which could result in an ignition.
- (2) Replace batteries with the new ones before the end of their useful life as determined in the specifications. When the batteries near the end of their life (50% state of their initial discharge duration time) will shorten remarkably. Finally the batteries will lose their available capacity by either drying out their electrolyte (causing increase in their internal resistance) or an internal short-circuit. In such case, if the batteries go on charging, thermal runaway and/or leakage of electrolyte may occur. The batteries should be replaced before becoming in these state.

The expected life of the batteries(in trickle or float use)will decrease to half (50%) with each 10°C rise in temperature above 25°C. In particular, the life of the batteries will be shortened remarkably at approximately 40°C. Accordingly, precautions are required to prevent the use of batteries at high temperatures.

- (3) Avoid using organic solvents such as thinner, gasoline, lamp oil or benzine and liquid detergent to clean the batteries. These substances may cause the battery containers to crack or leak.

REQUEST

- (1) Keep the battery terminals clean in order to avoid interruption in the discharge and/or to maintain the charge.

7. Treatment at Emergency

WARNING

- (1) The batteries have toxic liquid - dilute sulfuric acid solution in them. If the acid comes into contact with skin or clothes, wash skin or cloth with lots of clean water to prevent scalding from occurring. If the acid should come into contact with the eyes, wash the eyes with lots of clean water and consult a physician immediately to prevent possible loss of sight.

- (2) Check the batteries visually for any sign of irregularities in appearance. If any damage exists such as cracks, deformation, leakage of electrolyte, or corrosion, the batteries must be replaced with the new ones. Irregularities in the batteries could result in bodily injury, electrolyte leakage, ignition or explosion, if used. Furthermore, make sure the batteries are clean and free from dirt and dust.
- (3) Turn off a power supply of any battery that is found to have transformation with heat on the battery containers or cracks of covered lead wires or plates. Then contact Voltus Battery Corp to ask treatment. These corrosions in the batteries could result in a fire or an accident by an electric shock, if used.

8. Storage

CAUTION

- (1) Store the batteries in a fixed position separate from metal or other conductive materials.
- (2) Keep the batteries from rain water that could cause corrosion on the terminals of the batteries.
- (3) Keep the batteries right-side-up during transportation and do not give any abnormally strong shock and jolt to the batteries. Transporting the batteries in an abnormal position or handling them roughly could destroy the batteries or cause their characteristics to deteriorate.
- (4) When storing the batteries, be sure to remove them from the equipment or disconnect them from the charger and the load, then store them at room temperature or lower temperature. Do not store the batteries at direct sunlight, higher temperature or high humidity. To do so cause the batteries short life, performance deterioration or corrosion on terminals.

REQUEST

- (1) Charge the batteries at least once every 6 months if they are stored at 25°C. Use the charge method specified in "3. Preparation Prior to Use". The interval of this charge should be reduced to 50% by each 10°C rise in temperature above 25°C.
The self-discharge rate doubles for each 10°C in temperature. If they are stored for a long time in a discharged state, their capacity may not recover even after charge. If the batteries are stored for more than a year at room temperature, the life of the batteries may be shortened.
- (2) Store the batteries starting from the fully charged state to prevent the life of the batteries being shortened.
- (3) Use the batteries as quickly as possible after receiving them as they gradually deteriorate even under proper storage conditions.

9. Disposal and Recycling

CAUTION

- (1) Please write the information about battery recycling on the equipment, the package, the carton, the instruction manual etc. in countries where legal or voluntary regulations on battery recycling are applicable.
- (2) Design the equipment such that exchange and disposal of the batteries can be undertaken easily.
- (3) Used batteries should be recycled. When returning used batteries, insulate their terminals using adhesive tape, etc. Even used batteries still have electrical charge and an explosion or a fire may occur, if proper insulation is not given on the terminals of the used batteries.